

Series 4, Side-by-Side Fridge, 178.7 x 90.8 cm, Inox-look KAN93VL30N



A++

- **A++ energy class refrigerator consumes 40% less energy than A energy class.**
- **XXL capacity: extra space for your food when you need it.**
- **Intelligent Inverter Technology ensures a stable temperature control and efficient performance.**
- **Super Cooling function: cools new food placed inside faster, thus protecting already cooled food.**
- **LED lighting: keep your groceries in perfect view.**



Built-in / Free-standing:	Free-standing
Number of compressors:	1
Number of independent cooling systems:	1
Width of the appliance:	908 mm
Height:	1787 mm
Depth:	707 mm
Net weight:	99.2 kg
Min. required niche size for installation (HxWxD):	mm
Door panel options:	Not possible
Door hinge:	left and right
Number of Adjustable Shelves in fridge compartment:	0
Shelves for Bottles:	No
Frost free system:	Freezer
Interior ventilator:	No
Reversible Door Hinge:	No
Length electrical supply cord:	170.0 cm
Noise level:	42 dB(A) re 1 pW
Connection rating:	240 W
Fuse protection:	10 A
Voltage:	220-240 V
Frequency:	50-60 Hz
Energy efficiency class:	
Energy consumption annual - NEW (2010/30/EC):	363.00 kWh/annum
Refrigerator Net capacity - NEW (2010/30/EC):	371 l
Freezer Net capacity - NEW (2010/30/EC):	189 l
Energy consumption:	kWh
Freezing capacity) - NEW (2010/30/EC):	12 kg/24h
Freezing capacity:	kg
Storage Period in Event of Power Failure (h):	4 h
Included accessories:	1 x egg tray



**Series 4, Side-by-Side Fridge, 178.7 x
90.8 cm, Inox-look
KAN93VL30N**

Measurements in mm

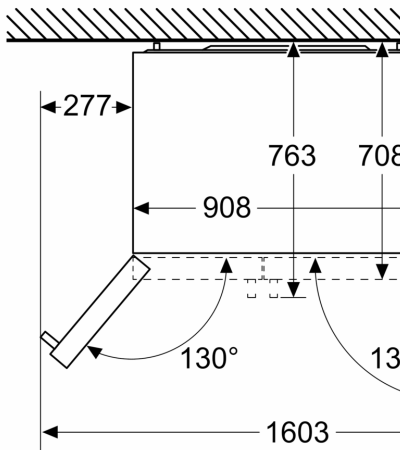

Measurements in mm

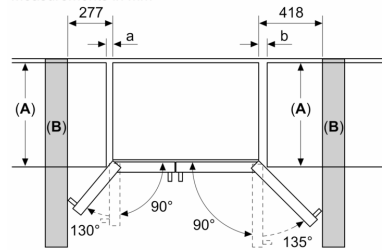

Measurements in mm

